



1



2

MATERIAL

Segjärn, sandblästrad matt yta



3

CYLINDRISKT HANDTAG

Svartoxiderat stål.



4

POSITIONERINGSSTIFT OCH STOPP

Härdat stål.



5

STANDARDUTFÖRANDE

- **GN 558-B**: bussning med brotschat hål H7.
- **GN 558-K**: bussning med brotschat hål H7 och kilspår i enlighet med DIN 6885/2 tolerans P9 (se sidan A-16).



6

KÄNNETECKEN OCH ANVÄNDNING

GN 558 manöverspakar används normalt för positionering av axlar i bestämda fasta lägen

Spakarna kan även levereras ej monterade.



8



9



10



11



12



13



14



15



16



17



18

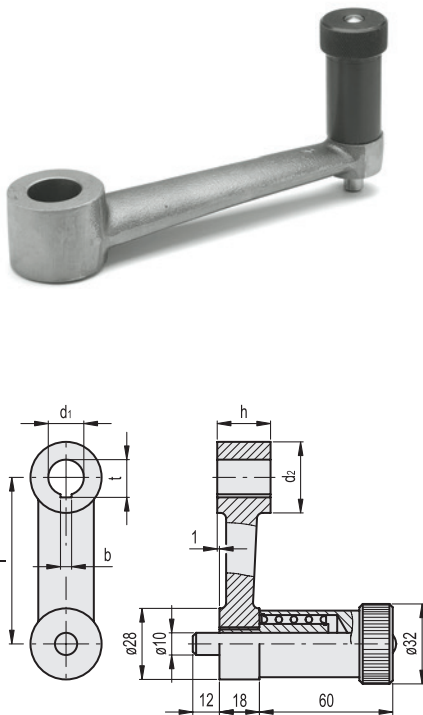

Kod	Benämning	l	d1 H7	d2	h	bp9	t	Δ
GN.23101	GN 558-75-B16	75	16	32	24	-	-	544
GN.23102	GN 558-75-K16	75	16	32	24	5	17.3	537
GN.23111	GN 558-90-B18	90	18	34	26	-	-	588
GN.23112	GN 558-90-K18	90	18	34	26	6	19.7	583
GN.23121	GN 558-110-B20	110	20	36	30	-	-	694
GN.23122	GN 558-110-K20	110	20	36	30	6	21.7	689
GN.23131	GN 558-135-B22	135	22	42	32	-	-	823
GN.23132	GN 558-135-K22	135	22	42	32	6	23.7	818
GN.23141	GN 558-165-B24	165	24	44	36	-	-	994
GN.23142	GN 558-165-K24	165	24	44	36	8	25.7	988